

FLUKE®

Biomedical

VT650/VT900

Gas Flow Analyzer

Getting Started Manual



PN 4937369

October 2017, Rev. 1

©2017 Fluke Corporation. All rights reserved. All product names are trademarks of their respective companies.

Warranty and Product Support

Fluke Biomedical warrants this instrument against defects in materials and workmanship for one year from the date of original purchase OR two years if at the end of your first year you send the instrument to a Fluke Biomedical service center for calibration. You will be charged our customary fee for such calibration. During the warranty period, we will repair or at our option replace, at no charge, a product that proves to be defective, provided you return the product, shipping prepaid, to Fluke Biomedical. This warranty covers the original purchaser only and is not transferable. The warranty does not apply if the product has been damaged by accident or misuse or has been serviced or modified by anyone other than an authorized Fluke Biomedical service facility. NO OTHER WARRANTIES, SUCH AS FITNESS FOR A PARTICULAR PURPOSE, ARE EXPRESSED OR IMPLIED. FLUKE SHALL NOT BE LIABLE FOR ANY SPECIAL, INDIRECT, INCIDENTAL OR CONSEQUENTIAL DAMAGES OR LOSSES, INCLUDING LOSS OF DATA, ARISING FROM ANY CAUSE OR THEORY.

This warranty covers only serialized products and their accessory items that bear a distinct serial number tag. Recalibration of instruments is not covered under the warranty.

This warranty gives you specific legal rights and you may also have other rights that vary in different jurisdictions. Since some jurisdictions do not allow the exclusion or limitation of an implied warranty or of incidental or consequential damages, this limitation of liability may not apply to you. If any provision of this warranty is held invalid or unenforceable by a court or other decision-maker of competent jurisdiction, such holding will not affect the validity or enforceability of any other provision.

7/07

Notices

All Rights Reserved

© Copyright 2017, Fluke Biomedical. No part of this publication may be reproduced, transmitted, transcribed, stored in a retrieval system, or translated into any language without the written permission of Fluke Biomedical.

Copyright Release

Fluke Biomedical agrees to a limited copyright release that allows you to reproduce manuals and other printed materials for use in service training programs and other technical publications. If you would like other reproductions or distributions, submit a written request to Fluke Biomedical.

Unpacking and Inspection

Follow standard receiving practices upon receipt of the instrument. Check the shipping carton for damage. If damage is found, stop unpacking the instrument. Notify the carrier and ask for an agent to be present while the instrument is unpacked. There are no special unpacking instructions, but be careful not to damage the instrument when unpacking it. Inspect the instrument for physical damage such as bent or broken parts, dents, or scratches.

Technical Support

For application support or answers to technical questions, either email techservices@flukebiomedical.com or call 1-800- 850-4608 or 1-440-248-9300 (Europe +31-40-2965314).

Claims

Our routine method of shipment is via common carrier, FOB origin. Upon delivery, if physical damage is found, retain all packing materials in their original condition and contact the carrier immediately to file a claim. If the instrument is delivered in good physical condition but does not operate within specifications, or if there are any other problems not caused by shipping damage, please contact Fluke Biomedical or your local sales representative.

Returns and Repairs

Return Procedure

All items being returned (including all warranty-claim shipments) must be sent freight-prepaid to our factory location. When you return an instrument to Fluke Biomedical, we recommend using United Parcel Service, Federal Express, or Air Parcel Post. We also recommend that you insure your shipment for its actual replacement cost. Fluke Biomedical will not be responsible for lost shipments or instruments that are received in damaged condition due to improper packaging or handling.

Use the original carton and packaging material for shipment. If they are not available, we recommend the following guide for repackaging:

- Use a double-walled carton of sufficient strength for the weight being shipped.
- Use heavy paper or cardboard to protect all instrument surfaces. Use nonabrasive material around all projecting parts.
- Use at least four inches of tightly packed, industry-approved, shock-absorbent material around the instrument.

Returns for partial refund/credit:

Every product returned for refund/credit must be accompanied by a Return Material Authorization (RMA) number, obtained from our Order Entry Group at 1-440-498-2560.

Repair and calibration:

To find the nearest service center, go to www.flukebiomedical.com/service or

In the U.S.A. and Asia:
Cleveland Calibration Lab
Tel: 1-800-850-4608 x2564
Email: globalcal@flukebiomedical.com

In Europe, Middle East, and Africa:
Eindhoven Calibration Lab
Tel: +31-40-2675300
Email: ServiceDesk@fluke.com

To ensure the accuracy of the Product is maintained at a high level, Fluke Biomedical recommends the product be calibrated at least once every 12 months. Calibration must be done by qualified personnel. Contact your local Fluke Biomedical representative for calibration.

Certification

This instrument was thoroughly tested and inspected. It was found to meet Fluke Biomedical's manufacturing specifications when it was shipped from the factory. Calibration measurements are traceable to the National Institute of Standards and Technology (NIST). Devices for which there are no NIST calibration standards are measured against in-house performance standards using accepted test procedures.

WARNING

Unauthorized user modifications or application beyond the published specifications may result in electrical shock hazards or improper operation. Fluke Biomedical will not be responsible for any injuries sustained due to unauthorized equipment modifications.

Restrictions and Liabilities

Information in this document is subject to change and does not represent a commitment by Fluke Biomedical. Changes made to the information in this document will be incorporated in new editions of the publication. No responsibility is assumed by Fluke Biomedical for the use or reliability of software or equipment that is not supplied by Fluke Biomedical, or by its affiliated dealers.

Manufacturing Location

The VT650/VT900 Gas Flow Analyzer is manufactured at Fluke Biomedical, 6920 Seaway Blvd., Everett, WA, U.S.A.

Table of Contents

| Title | Page |
|--------------------------------|------|
| Introduction | 1 |
| Safety Information | 1 |
| Unpacking and Inspection | 5 |
| Power On the Analyzer | 5 |
| The Analyzer | 6 |
| Maintenance | 8 |
| Abbreviations | 9 |
| Specifications | 10 |

Introduction

The VT650/VT900 Gas Flow Analyzer (the Analyzer or Product), is a general purpose gas flow analyzer with special features for testing mechanical patient ventilators. The Analyzer measures bi-directional air flow, high and differential low pressure, barometric pressure, oxygen concentration, airway pressure, airway temperature, and airway humidity. The VT900 also measures ultra-low flow (± 750 ml/min) and ultra-low pressure (0 mbar to 10 mbar). The Analyzer can be controlled externally using USB commands or automated with available software. The Analyzer operates on a rechargeable Li-Ion battery or external power supply for stationary or portable use. All figures show the VT900 unless otherwise noted.

Go to www.flukebiomedical.com to find more information and to download the latest Getting Started Manual, Users Manual, or manual supplement.

Safety Information

A **Warning** identifies conditions and actions that pose hazards to the user; a **Caution** identifies conditions and actions that may damage the Product or the equipment under test.

Warning

To prevent possible electrical shock, fire, or personal injury:

- **Read all safety information before you use the Product.**
- **Use the Product only as specified, or the protection supplied by the Product can be compromised.**
- **Carefully read all instructions.**
- **Do not use the Product around explosive gas, vapor, or in damp or wet environments.**

- **Use this Product indoors only.**
- **Do not use the Product if it operates incorrectly.**
- **Disable the Product if it is damaged.**
- **Do not use the Product if it is damaged.**
- **The battery door must be closed and locked before you operate the Product.**
- **Recharge the batteries when the low battery indicator shows to prevent incorrect measurements.**
- **Remove all probes, test leads, and accessories before the battery door is opened.**
- **Remove all probes, test leads, and accessories that are not necessary for the measurement.**
- **Use only specified replacement parts.**
- **Have an approved technician repair the Product.**
- **Batteries contain hazardous chemicals that can cause burns or explode. If exposure to chemicals occurs, clean with water and get medical aid.**
- **Do not disassemble the battery.**
- **Repair the Product before use if the battery leaks.**
- **Use only Fluke approved power adapters to charge the battery.**
- **Do not short the battery terminals together.**
- **Do not disassemble or crush battery cells and battery packs.**
- **Do not keep cells or batteries in a container where the terminals can be shorted.**

- Do not put battery cells and battery packs near heat or fire. Do not put in sunlight.
- Remove the batteries if the Product is not used for an extended period of time, or if stored in temperatures above 50 °C. If the batteries are not removed, battery leakage can damage the Product.













⚠ Caution

To avoid damage to the Product and avoid adverse affects on the Product performance:

- Do not put metal objects into connectors.
 - Always use the external flow filter on the main airflow channel inlet. This helps reduce turbulence and keeps out small particles that could damage the flow sensor.
- Measure only dry gases. Do not use humidified gases.
 - To avoid damage to the sensor, make sure the pressure inside the high-flow port does not exceed 5 psi. Make sure the pressure inside the ultra-low-flow port does not exceed 25 psi.
 - To avoid damage to the sensor, make sure applied pressure does not exceed 188 psi (13 bar) on the high-pressure port. Make sure applied pressure does not exceed 5 psi on the low-pressure port and ultra-low-pressure port.
 - Do not drop the Product and avoid mechanical abuse that could cause a shift in the calibrated settings.

Symbols used on the Analyzer and in this manual are explained in Table 1.

Table 1. Symbols

| Symbol | Meaning | Symbol | Meaning |
|---|--|---|---|
|  | WARNING. RISK OF DANGER. |  | WARNING. HAZARDOUS VOLTAGE. Risk of electric shock. |
|  | Consult user documentation. |  | Conforms to European Union directives. |
|  | Power button |  | Conforms to relevant North American Safety Standards. |
|  | Li-ion Battery |  | Conforms to relevant Australian Safety and EMC standards. |
|  | Power input 15 V dc 2.0 A |  | Conforms to relevant South Korean EMC Standards. |
|  | Conforms to the Appliance Efficiency Regulation (California Code of Regulations, Title 20, Sections 1601 through 1608), for small battery charging systems. | | |
|  | This product complies with the WEEE Directive marking requirements. The affixed label indicates that you must not discard this electrical/electronic product in domestic household waste. Product Category: With reference to the equipment types in the WEEE Directive Annex I, this product is classed as category 9 "Monitoring and Control Instrumentation" product. Do not dispose of this product as unsorted municipal waste. | | |

Unpacking and Inspection

Make sure you do not damage the Analyzer as you unpack.

- Inspect the shipping carton for damage.
 - If there is no damage, remove the Analyzer from the shipping case. Save the box and packing materials.
 - If the shipping carton is damaged, carefully continue to unpack the Analyzer. Note any dents and scratches on the Analyzer. Save the damaged shipping carton and packing material for the carrier's inspection.
- Do a visual inspection. Make sure the Analyzer is intact. If there is any physical damage, such as bent or broken parts, dents, or scratches, call a Fluke Biomedical Service Center immediately. To return the Analyzer to Fluke Biomedical for service see *Returns and Repairs* .

- Check the standard accessories. If any accessories are missing, contact a Fluke Biomedical Service Center.

Fluke Biomedical recommends storing the Analyzer in the carry case. Do not store the Analyzer where there is vibration.

Power On the Analyzer

To power on the Analyzer, push ⓘ.

Always use an external flow filter on the main airflow channel inlet. The filter helps reduce turbulence and keeps out small particles that could damage the flow sensor.

The Analyzer

Table 1 shows the top of the Analyzer.

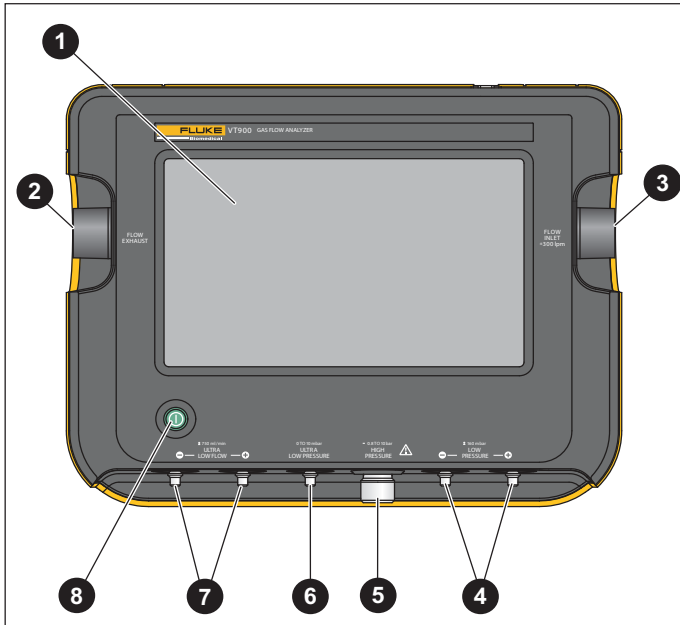

- 1 Touchsreen LCD
- 2 Flow exhaust
- 3 Flow inlet
- 4 Low pressure + and -
- 5 High pressure and vacuum
- 6 Ultra-low pressure (VT900)
- 7 Ultra-low flow + and - (VT900)
- 8 Power button

Figure 1. Top of the Analyzer

Figure 2 shows the back of the Analyzer.

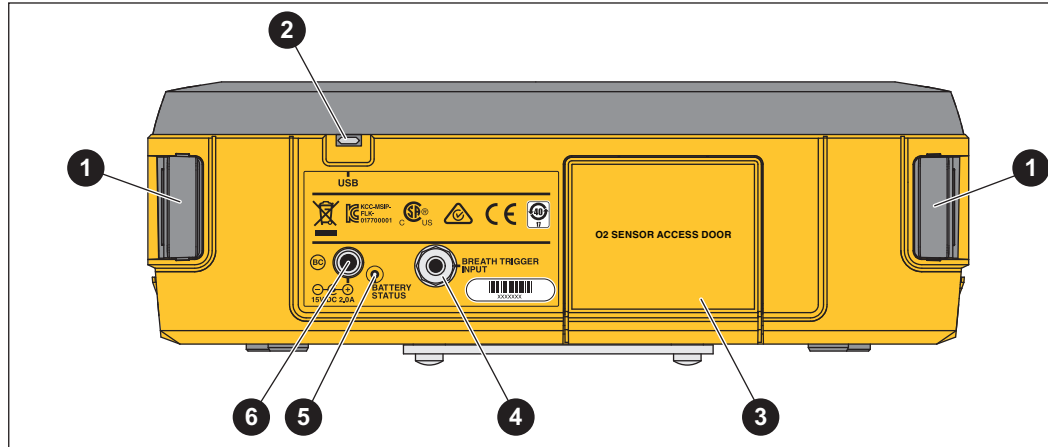

Figure 2. Back of the Analyzer

- | | |
|-------------------------------------|---|
| 1 Handle/shoulder strap clip | 4 External trigger input (VT900) |
| 2 Micro USB port | 5 Battery status indicator |
| 3 Oxygen sensor door | 6 External dc power input |

Figure 3 shows the bottom of the Analyzer.

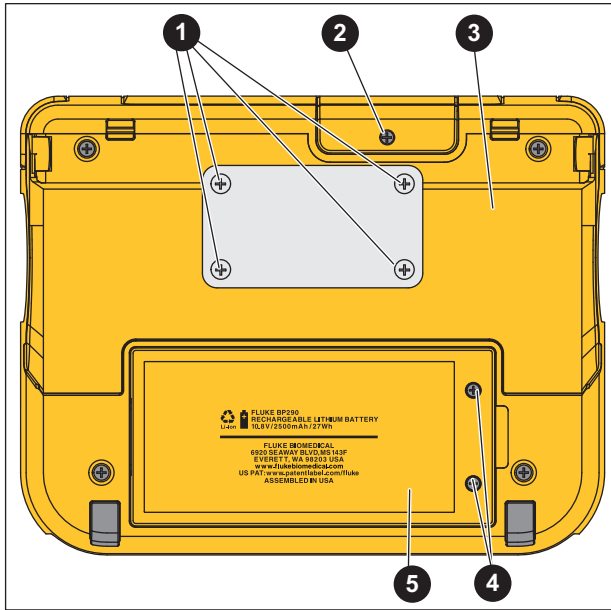

Figure 3. Bottom of the Analyzer

- 1 VESA mount points (FDMI MIS-C, C fits WxH of 75 mm x 35 mm)
- 2 Oxygen sensor door screw
- 3 Bail
- 4 Battery door screws
- 5 Battery door

Maintenance

Clean the exterior of the Analyzer occasionally with a cloth dampened with a mild detergent solution. To remove stains and clean the Analyzer, use a solution of 70 % isopropyl alcohol. Fluke Biomedical does not recommend any other solvents.

⚠ Caution

To prevent damage to the Analyzer or adverse affects on the Analyzer performance:

- **Do not spray liquid directly on the Analyzer. Do not immerse the Analyzer.**
- **Other than replacement of minor components, such as the oxygen sensor, all Analyzer service should be done by qualified service personnel.**
- **To keep foreign debris from entering the Analyzer, use flow and pressure protective caps when transporting the Analyzer.**
- **To keep the Analyzer under warranty, make sure the Analyzer is calibrated by qualified service personnel only.**

Abbreviations

| Parameter | Abbreviation |
|--|--------------|
| Inspiratory Tidal Volume | Vti |
| Expiratory Tidal Volume | Vte |
| Minute Volume | MV |
| Breath Rate | BPM |
| Inspiratory to Expiratory Time Ratio (I:E Ratio) | I:E |
| Peak Inspiratory Pressure | PIP |
| Inspiratory Pause Pressure | IPP |
| Mean Airway Pressure | MAP |
| Positive End-Expiratory Pressure | PEEP |
| Lung Compliance ^[1] | CMPL |
| Inspiratory Time | Ti |
| Inspiratory Hold Time | TiH |
| Expiratory Time | Te |
| Expiratory Hold Time | TeH |
| Peak Inspiratory Flow | PIF |
| Peak Expiratory Flow | PEF |
| [1] Inspiratory pause time >0.5 sec | |

Specifications

Specifications are based on a one-year calibration cycle and apply to ambient temperature 18 °C to 28 °C unless stated otherwise.

Display..... 17 cm (7 in), 800 x 480 touchscreen LCD

Output Ports Micro-USB

Environmental Conditions

Operating Temperature..... 10 °C to 40 °C

Storage Temperature..... -20 °C to +60 °C

Note

For storage temperatures below -15 °C or above +50 °C, remove the oxygen sensor.

Humidity 10 % to 90 % non-condensing

Altitude 3000 m

Power

AC adapter

Input Voltage Range 100 V ac to 240 V ac

Input Frequency

Range..... 50 Hz/60 Hz

Output dc voltage..... 15 V

Battery

Rechargeable Li-Ion

Battery 10.8 V, 2.5 Ah, 27 Wh, 3ICR19/66

Discharge temperature... 0 °C to 50 °C

Charge temperature 0 °C to 40 °C

Battery life 8 hours

Battery charge time 5 hours

Safety

General IEC 61010-1: Pollution Degree 2

Lithium Battery IEC 62133

Electromagnetic Compatibility (EMC)

International IEC 61326-1: Controlled Electromagnetic Environment
CISPR 11: Group 1, Class A

Group 1: Equipment has intentionally generated and/or uses conductively-coupled radio frequency energy that is necessary for the internal function of the equipment itself.

Class A: Equipment is suitable for use in all establishments other than domestic and those directly connected to a low-voltage power supply network that supplies buildings used for domestic purposes. There may be potential difficulties in ensuring electromagnetic compatibility in other environments due to conducted and radiated disturbances.

Caution: This equipment is not intended for use in residential environments and may not provide adequate protection to radio reception in such environments.

Emissions that exceed the levels required by CISPR 11 can occur when the equipment is connected to a test object.

Korea (KCC) Class A Equipment (Industrial Broadcasting & Communication Equipment)

Class A: Equipment meets requirements for industrial electromagnetic wave equipment and the seller or user should take notice of it. This equipment is intended for use in business environments and not to be used in homes.

USA (FCC)..... 47 CFR 15 subpart B. This product is considered an exempt device per clause 15.103.